

IR9000 Polarised/Retro-Reflective photocell

Features:

1. Polarised/Retro-Reflective photocell
2. Red infrared led element
3. Sensing range 10 metre
4. IP-66 water proof
5. IP-66 water proof cable gland
6. PMMA upper casing, anti fog/dew/rains
7. Round shape reflector-Dia.: 80mm
8. Input volt.: AC/DC 12~250V
9. Twin colors Led indicator for beam alignment
10. Tamper switches included

Applications:

1. Gates
2. Overhead door
3. Swing gate
4. Sliding door
5. Perimeter protection
6. Window
7. Terrace
8. Warehouse
9. Parking lot
10. Automation control

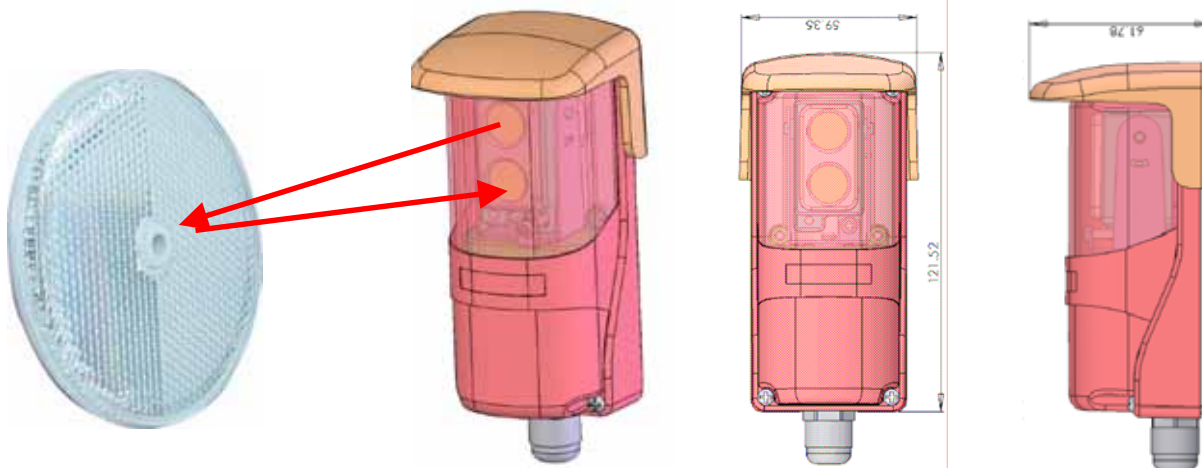

Input Volt.	ac/dc 12~250V (Non Polarity)
Tx Led Element	Red infrared/Wave Length 625nm
Beam Spreading angle	1.5 degree (half angle)
Contact Capacity	0.5A/120VAC (1A/30VDC)
Response Time	10 msec
Delay Time of Relay	100 msec
Sensing Range	10 meters
Led Indicators	Red led Off: Beam aligned/Red led On:Beam broken Red led flash: Beam alignment signal weak (Re-align) Green led on: Beam aligned proper
Additional Function	Tamper switches
Wiring Connection	Terminal block/Cable gland (IP-66)
Housing Material	Bottom casing:ABS/Upper casing:PMMA
IP	IP-66
Environment/Storage Temp.	-25~60 / -35~80
Dimension	122 (H) X 60 (W) X 62 (T) mm

Construction

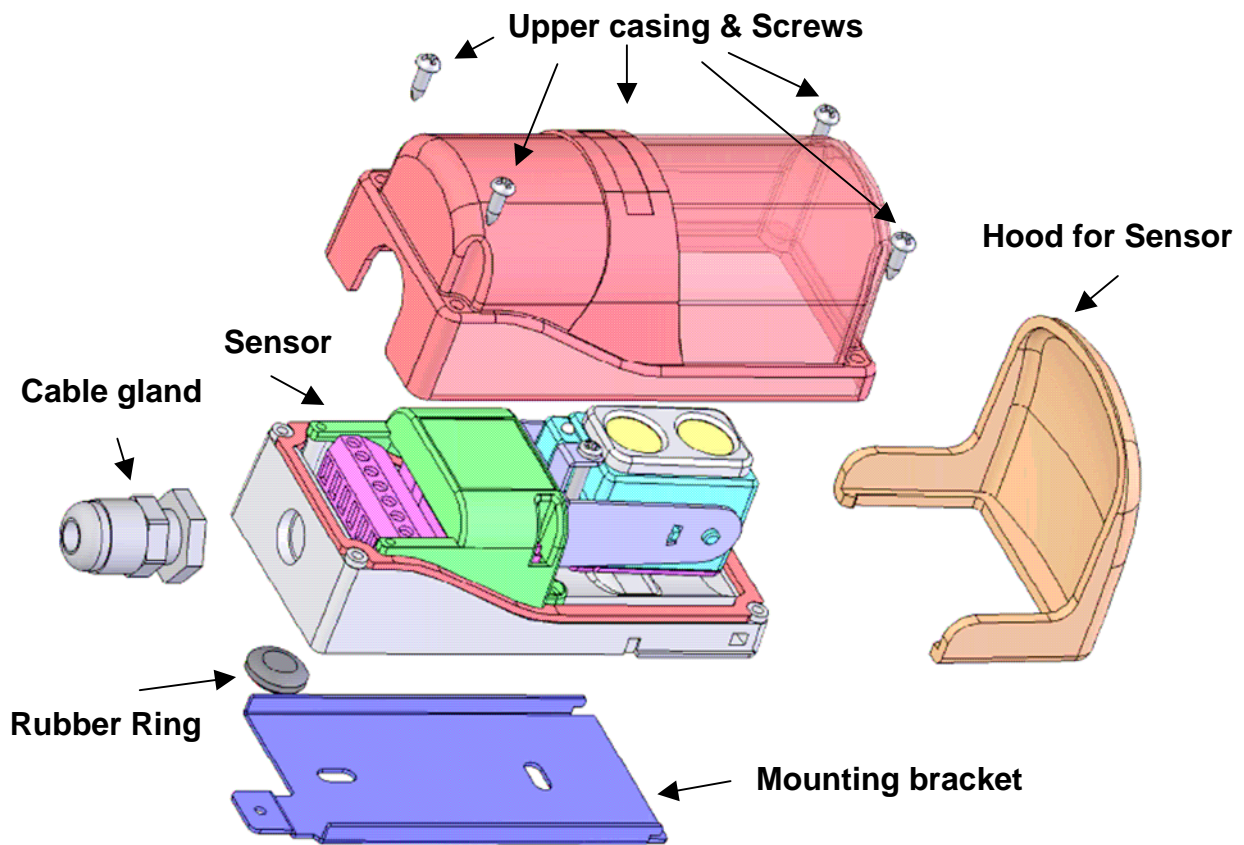

Wiring Connection:

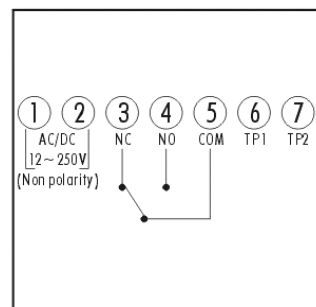
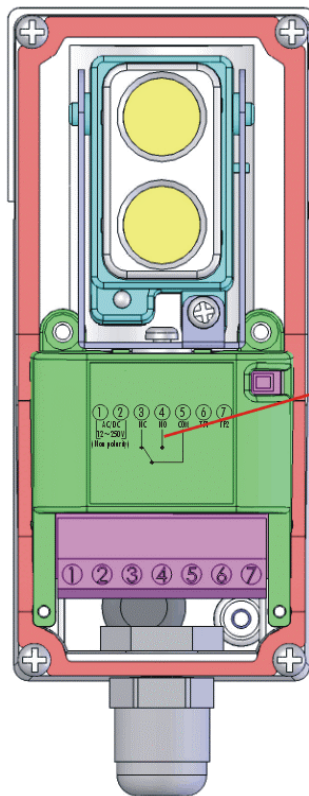

23.3(W)mm

22.6(H)mm

Additional function:
 TP1/TP2--Tamper switches,
 can be connected with control
 panel or siren as burglar alarm